



Type VC62
DN 15 – 50
PN16-PN160

Forged Globe Valve

Butt-Welded, Flanged

Data Sheet

Edition: EN 9 / 2014

© VCEN VALVE CO.,LTD.
Anfeng industrial zone, Oubei, Zhejiang, China
T: +86 67969666, F: +86 67988805
E: vcen@vcenvalve.com, W: www.vcenvalve.com

We focus on quality
www.vcenvalve.com

Application

- Designed for closing or throttling the liquid and gaseous medium
- **Fluids**
Water, steam, air, crude petroleum and petroleum products, natural gas, gas condensate, technological solutions, oxygen, liquid and non-aggressive gases
- **Industry**
Power engineering, chemical and petrochemical industry

Technical description

- Stem is rotating, rising
- Valve opening is provided slowly, with gradual suspension of the stroke, to prevent hydraulic and thermal shocks in the valve
- Shutt-off valves can be operated in position open-close, throttling valve can be operated also in an intermediate position

Testing

- The valves are pressure tested by water for strength and tightness in accordance with EN-12266
Certification: PED/97/23/EC
shell test : nominal pressure (PN)X1.5
Tightness of seat : nominal pressure (PN)X1.1

Installation

- The valves may be installed in any position, direction of the flow is under the plug

Connection

- Butt-welded according to EN-12627, flanged according to EN1092-1 or to customer request
- Face to face dimensions according to EN-558-1

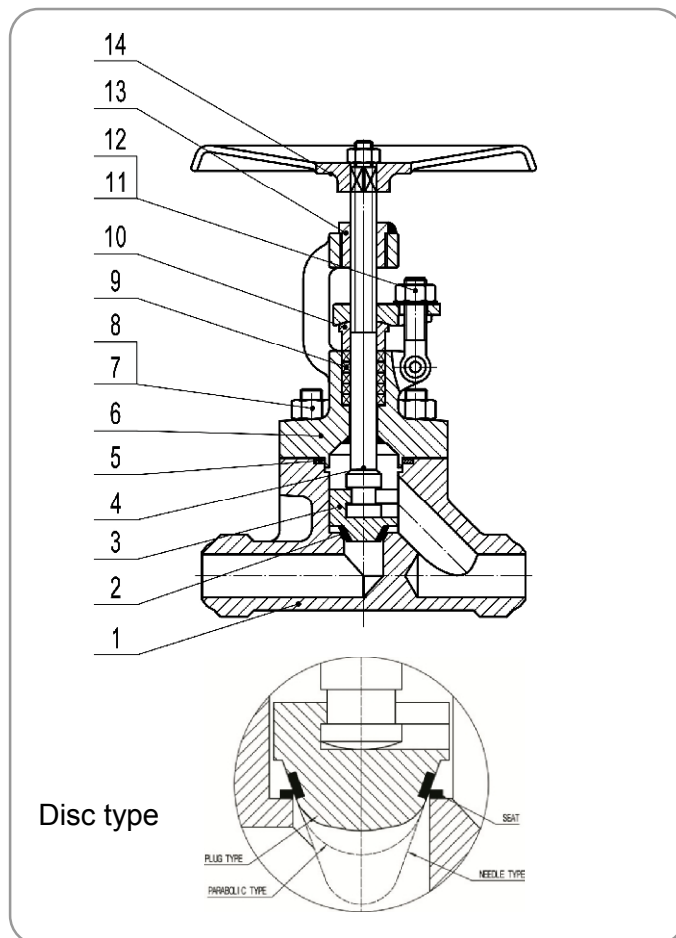

Operation

- Hand wheel (with locking device, if required)
- Electric actuator
- Flange ISO 5210 (ready for actuator)

Copyright

All rights reserved. No content provided herein may be copied, distributed or otherwise reproduced without previous written approval of the company
YONGJIA VCEN VALVE CO.,LTD

© VCEN VALVE CO.,LTD CHINA 2014

Contact

VCEN VALVE CO.,LTD
Anfeng Industrial Zone,Oubei
Town,Yongjia County Wenzhou
City,Zhejiang Province,China

T: +86 6796 9666
F: +86 6798 8805
E: vcen@vcenvalve.com
W: www.vcenvalve.com

Materials of main parts

Pos.	Name	Material
1	Body	1.0619 (A216 WCB), 1.7357 (A217 WC6), 1.4408 (A351 CF8M)
2	Seat	13Cr, STL6
3	Disc	A105,F316
4	Stem	X20Cr13, F316,
5	Gasket	Graphite + stainless steel
6	Bonnet	1.0619 (A216 WCB), 1.7357 (A217 WC6), 1.4408 (A351 CF8M)
7	Blot	A193 B7,A193 B16,A193 B8M
8	Nut	A194 2H,A194 4,A194 8M
9	Packing	Graphite
10	Gland	1.0619 (A216 WCB), 1.7357 (A217 WC6), 1.4408 (A351 CF8M)
11	Eyelet bolt	A193 B7,A193 B16,A193 B8M
12	Nut	A194 2H,A194 4,A194 8M
13	Screw	C.S
14	Handwheel	Steel

P-T data

Materiál	PN	Pracovní tlak MPa / Pracovní teplota °C													
		50	100	150	200	250	300	350	400	425	475	500	525	550	575
Carbon steel 1C1, A105/1,0460	16	1,58	1,46	1,43	1,38	1,32	1,22	1,17	1,15	0,91	-	-	-	-	-
	25	2,47	2,29	2,23	2,16	2,06	1,91	1,82	1,70	1,42	-	-	-	-	-
	40	3,95	3,66	3,57	3,46	3,29	3,06	2,92	2,72	2,27	-	-	-	-	-
Carbon steel 1C1, A105/1,0460	63	6,35	6,22	5,77	5,62	5,45	5,19	4,81	4,59	4,29	-	-	-	-	-
	100	9,88	9,15	8,92	8,65	8,23	7,64	7,29	6,81	5,67	-	-	-	-	-
	160	15,32	15,02	13,91	13,56	13,14	12,51	11,62	11,09	10,35	-	-	-	-	-
Alloy steel 1C9, 1,7357(F11)	63	6,43	6,40	6,19	5,96	5,74	5,33	5,00	4,55	4,36	3,94	3,14	2,26	1,58	1,09
	100	10,21	10,16	9,82	9,47	9,11	8,46	7,94	7,22	69,2	6,67	4,98	3,58	2,51	1,74
	160	15,51	15,44	14,92	14,39	13,85	12,86	12,07	10,97	10,53	10,14	9,50	5,45	3,81	2,64

Note: the temperature not listed in the table is selected by linear interpolation method

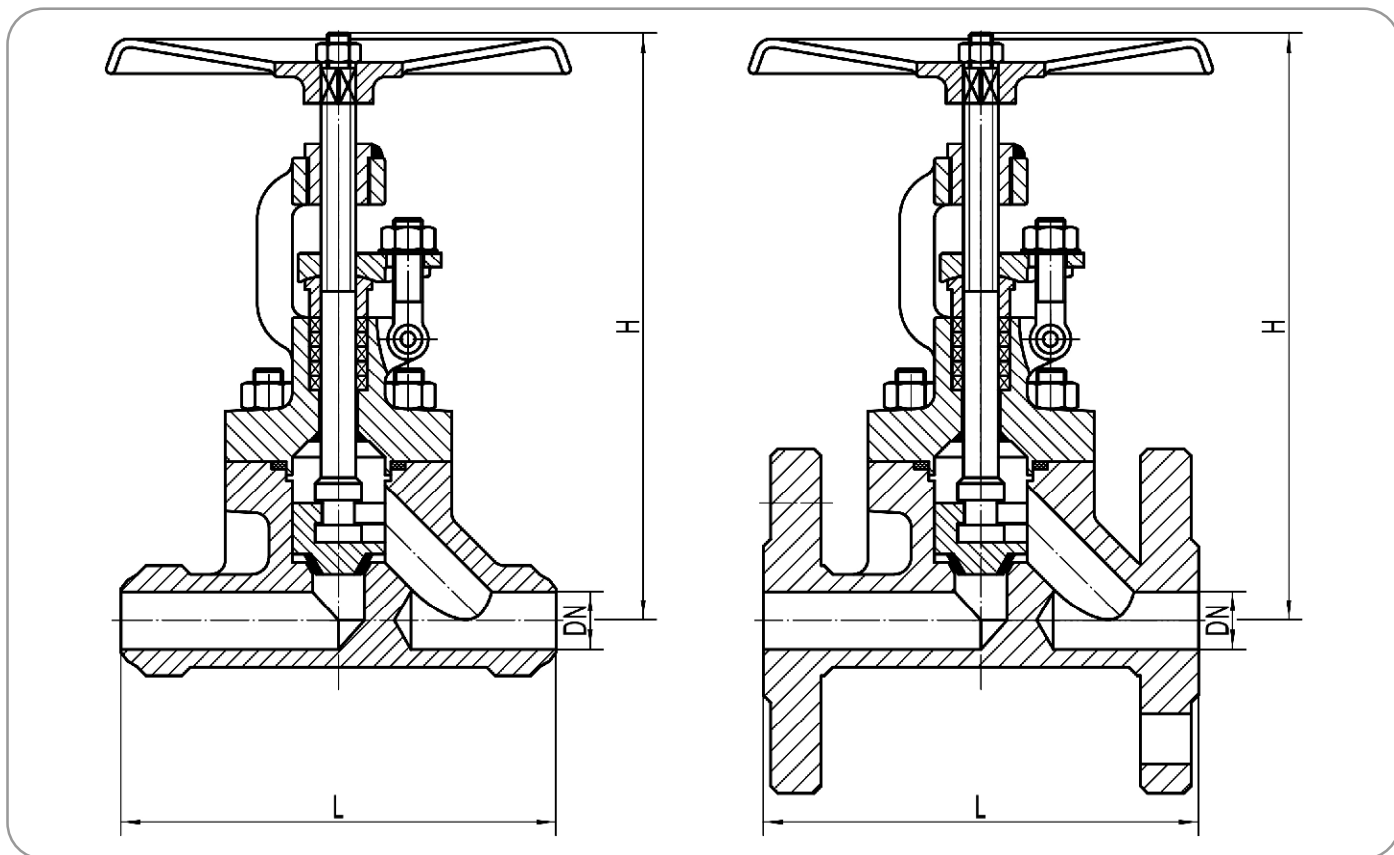

DN		15	20	25	32	40	50
L(mm) PN16-PN40		130	150	160	180	200	230
L(mm) PN63-PN160		150	150	160	180	210	250
H(mm) PN16-PN40		185	185	190	200	220	250
H(mm) PN63-PN160		200	200	220	245	252	270
STORKE(mm)		12	13	16	18	23	26
Weight (kg)	PN16	4.8	5.8	6.8	9.5	10.1	13.8
	PN25	4.8	5.8	6.8	9.5	10.1	14.0
FL	PN40	4.8	5.8	6.8	9.5	10.1	14.0
Weight (kg)	PN16	3.2	4.0	4.8	5.9	6.5	8.5
	PN25	3.2	4.0	4.8	5.9	6.5	8.5
BW	PN40	3.2	4.0	4.8	5.9	6.5	8.5
Weight (kg)	PN63	4.2	4.6	5.8	8.8	14	19
	PN100	4.2	4.6	5.8	8.8	14	19
BW	PN160	4.2	4.6	5.8	8.8	14	19